



Miovision Core & Miovision Core DCM Hardware Installation Manual

Copyright statement

© 2022 Miovision Technologies Incorporated.

The information contained in this guide ("Information") is proprietary information of Miovision Technologies Incorporated and/or its affiliates (individually and collectively, "Miovision") and subject to change without notice. Any disclosure, modification, copying, forwarding, or use of the Information, for any purpose, in part or in whole, is prohibited without the express written permission of Miovision.

The Information, and any and all intellectual property rights associated therewith, shall at all times remain the sole property of Miovision. Miovision products and services, to which this Information relates, are protected by Canadian and International patents and trademarks. The Information provided does not include any product or service warranties and any statements provided in the Information should not be interpreted as such.

All products and services (including without limitation, any software) described in the Information may only be used in accordance with the terms and conditions of any agreements between the recipient (or the recipient's organization) and Miovision, including without limitation any license rights granted therein.

Miovision trademarks and registered trademarks include:

Miovision, Miovision Core, Miovision Core DCM, Miovision DataLink, Miovision TrafficLink, Miovision Scout, Miovision Spectrum, and Smart Cities Start Here.

Table of Contents

Table of Contents	3
Getting started	5
Miovision Core Components	5
Physical Specifications	6
Miovision Core	6
Device weight (not including cables)	6
Dimensions	6
Miovision Core DCM	6
Device weight (not including cables)	6
Dimensions	6
Package Contents	7
Miovision Core	7
Optional Miovision Core Wires:	7
Miovision Core DCM	8
Optional Miovision Core DCM Wires:	8
Safety Recommendations	8
Installing the Miovision Core Antenna	9
Required tools (not included)	9
Installing SmartView 360	10
Installing Miovision Core	10
Planning your Miovision Core Installation	10
Installation Considerations in the Cabinet	11
Miovision Core Installation Steps	12
If Installing Miovision Core DCM	15
Start Up Miovision Core	16
Set up the Miovision Core DCM	17
Change the displayed language on Miovision Core DCM	17
Establishing camera connectivity for Detection or Counting	18
Camera statuses	18
Resolve IP address conflicts	20
Finish Up	20
Monitor Miovision Core DCM Detection	22
View Miovision Core DCM Detectors	22

Determining the status of detectors	22
Upgrade Miovision Core to Miovision Core DCM	23
Restarting Miovision Core	24
Review the Traffic Cabinet Before Leaving the Intersection	25
Miovision Technical Support	26

Getting started

This document contains all the information you need to install the Miovision Core® or Miovision Core® DCM hardware. This guide assumes that you have the requisite background knowledge and equipment to safely handle electronic components.

Miovision Core Components

The Miovision Core & Miovision Core with the Detection and Counts Module (DCM) is a combined hardware and software solution to help you manage your intersection through the Miovision TrafficLink™ web-based portal to make data-informed decisions. In addition to the portal, this solution requires a camera to be installed at the intersection.

Component	Description
TrafficLink portal	The TrafficLink portal is a web-based dashboard where you can remotely manage signals, retrieve signal performance measures, and view recorded video footage of your intersections.
Miovision Core	Miovision Core is the center of the Miovision in-cabinet communications, monitoring, and traffic operations and management solution. It gathers data from the existing controllers and devices and provides convenient, secure remote connectivity to the cabinet.
Miovision Core DCM	Miovision Core with the Detection and Counts Module (DCM). The DCM slots into the Miovision Core mainframe, providing the edge processing power necessary for the solution's specialized computer vision algorithms.

Physical Specifications

Miovision Core

Device weight (not including cables)	
Miovision Core	4.9 lbs (2.2 kg)
Dimensions	
Miovision Core	10.5 (h) x 3.0 (w) x 10.0 (d) in 266 (h) x 75 (w) x 254 mm (d)

Miovision Core DCM

Device weight (not including cables)	
Miovision Core DCM	6.3 lbs (2.9 kg)
Dimensions	
Miovision Core DCM	10.5 (h) x 3.0 (w) x 10.0 (d) in 266 (h) x 75 (w) x 254 (d)

Package Contents

Miovision Core

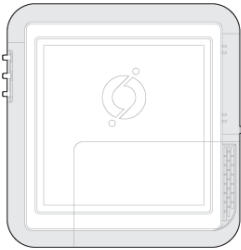

Miovision Core

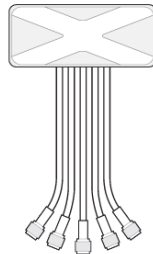

TrafficLink Antenna

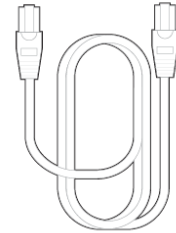

ITS Ready Ethernet Cable - 6ft (1.8m)

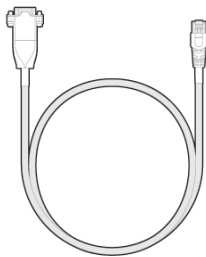

Core RJ45 to DB9 Serial Cable

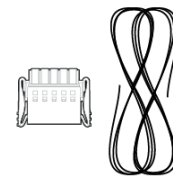

General Purpose I/O Header with hookup wires

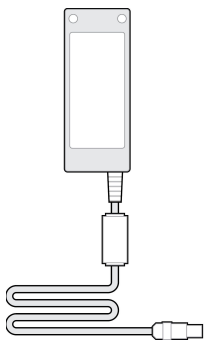

Core Universal Power Supply

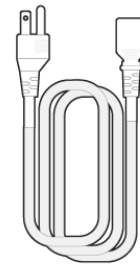

NEMA 5-15P to IEC-320-C13

Optional Miovision Core Wires:

- Core SDLC Y DB15 Cable
- Core SDLC Straight DB15 Cable

- Core SDLC Y DB25 Cable
- Core SDLC Straight DB25 Cable
- Core Priority Control IO Cable

Miovision Core DCM

The Miovision Core DCM includes all the above components with the addition of the following:



Miovision Core DCM
(DCM module is bottom right)

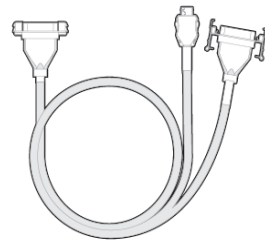

Core SDLC Y DB15 Cable

Optional Miovision Core DCM Wires:

- Core SDLC Straight DB15 Cable
- Core SDLC Y DB25 Cable
- Core SDLC Straight DB25 Cable
- Core Priority Control IO Cable

Safety Recommendations

To ensure safety during installation, follow these guidelines:

- It is recommended that a certified electrician performs the installation and that you follow the appropriate safety recommendations when installing the components.
- Do not install components if the conditions are not safe, such as during adverse weather situations.
- If possible, inspect the wires in the cabinet for any unsafe wear and replace them if necessary.

FCC NOTE: This equipment has been tested and found to comply with the limits for a Class A digital device, pursuant to part 15 of the FCC Rules. These limits are designed

to provide reasonable protection against harmful interference when the equipment is operated in a commercial environment. This equipment generates, uses, and can radiate radio frequency energy and, if not installed and used in accordance with the instruction manual, may cause harmful interference to radio communications. Operation of this equipment in a residential area is likely to cause harmful interference in which case the user will be required to correct the interference at his own expense.

Installing the Miovision Core Antenna

You can also review the following steps in the [Device Placement and TrafficLink Antenna Installation](#) video tutorial.

Planning your Miovision Core Installation

Before you begin, determine the best location in the cabinet for the antenna and the Miovision Core. You might need to move some of the existing equipment in the traffic cabinet to accommodate these devices. Make sure that you have access to terminal block wiring or a 110V-240V uninterrupted (non-GFCI) power source for the Miovision Core.

Required tools (not included)

- Drill and 7/8 in(22 mm) hole saw or punch
 - Industrial-strength cleaner
 - Heat gun if installing in temperatures under 41°F (5°C) ()
 - Dropcloth or container to catch drill filings
1. Mark a location for the antenna hole on top of the cabinet, at least 6 in (150 mm) from any edge. The antenna must be at least 8 in (200 mm) away from the device. Choose a location so that your drill bit or punch does not dent or puncture equipment in the cabinet.
 2. To contain sharp steel burrs that can cut wire or cause an electrical short, place a small container or cloth inside the cabinet, below the drill location, to catch any debris from drilling.
 3. Drill or punch a hole at the marked location.
 4. To provide a smooth surface for good adhesion, clean the surface where you are installing the antenna with industrial-strength cleaner. Remove any burrs caused by drilling.

Note: Make sure to completely remove any dirt, moisture, frost and steel burrs from drilling before continuing.

5. Remove the twist ties, nut, and washer from the antenna cables.
6. Guide the antenna cables through the hole in the cabinet as shown below..

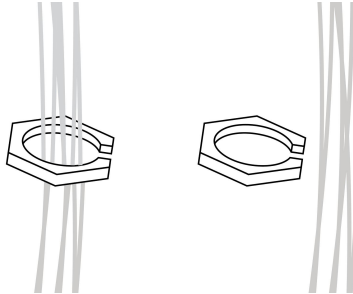

7. If the ambient temperature is below 41°F (5°C), use the heat gun to warm the surface where you are placing the antenna.
8. Remove the protective film from the adhesive pad on the bottom of the antenna and then firmly press the antenna onto the top of the cabinet.
9. Slide the washer and nut around the antenna cables.

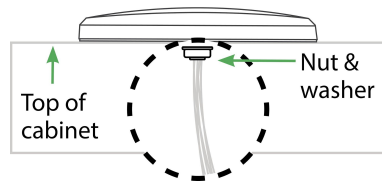

10. Hand tighten the nut.
11. Using the wrench, tighten the nut one full turn.
12. Visually inspect the antenna to make sure that the adhesive forms a tight seal on top of the cabinet.

Installing SmartView 360 camera

To install and set up the Miovision SmartView 360 camera, [Download the Miovision SmartView 360 Installation Guide.](#)

Installing Miovision Core

You can also review the following steps in the [Miovision Core Installation](#) video tutorial. .

Installation Considerations in the Cabinet

- For best ventilation, install the Miovision Core device vertically or horizontally with the glowing logo facing up. The status LEDs will flash red if the orientation is incorrect. .

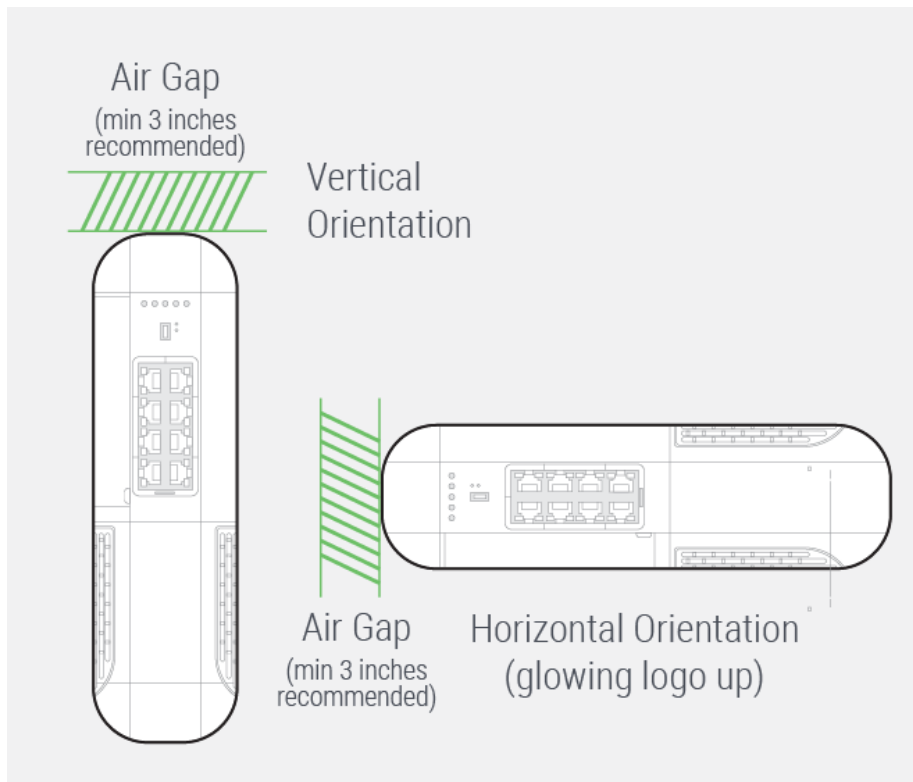

- Place the device with a minimum of 3 in (76 mm) around it for ventilation, connecting cables, and access to the components during maintenance.

Miovision Core Installation Steps

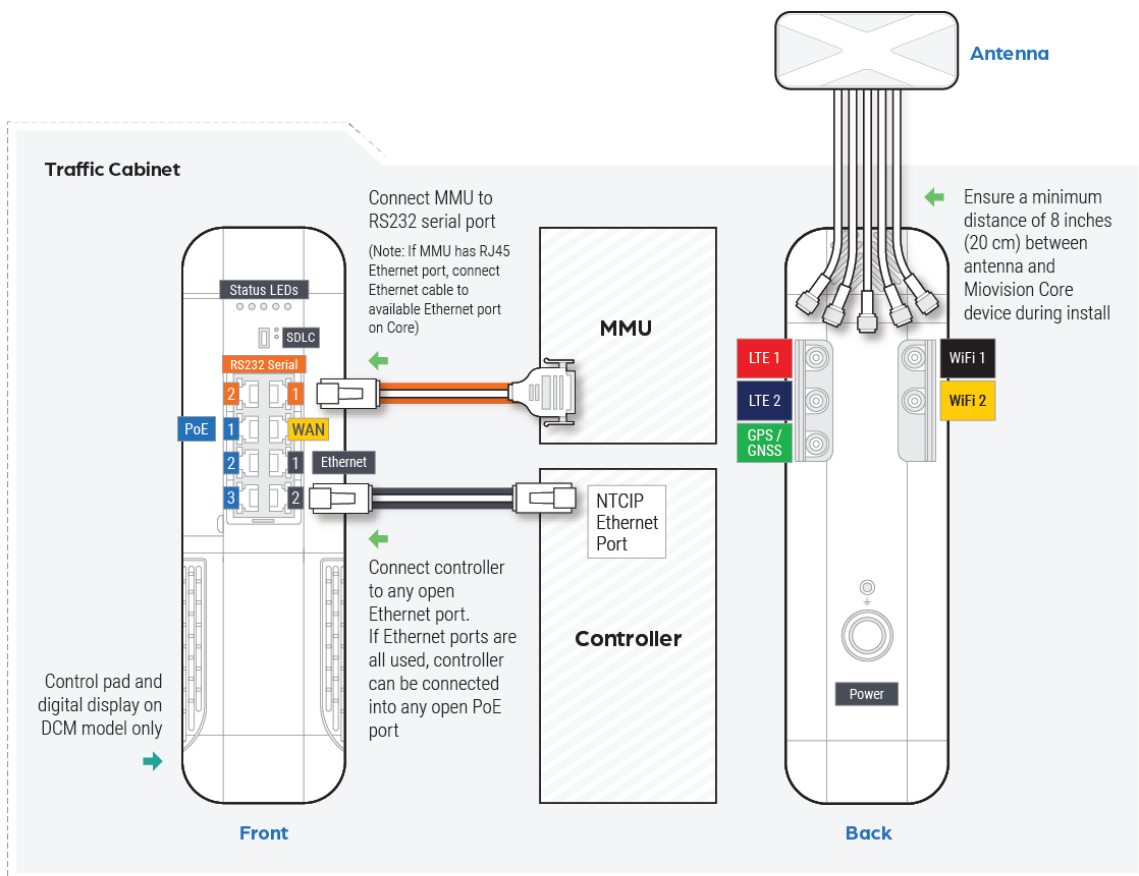

1. Place the Miovision Core in the planned location in the cabinet.
2. Using the color coding on each antenna cable as a guide, connect each antenna cable to the corresponding connector on the Miovision Core.

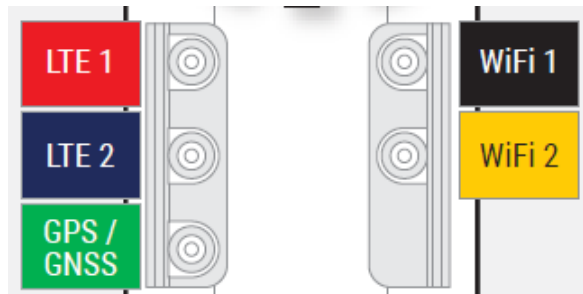

3. Plug your NTCIP compatible controller into ports 1 or 2 (gray).

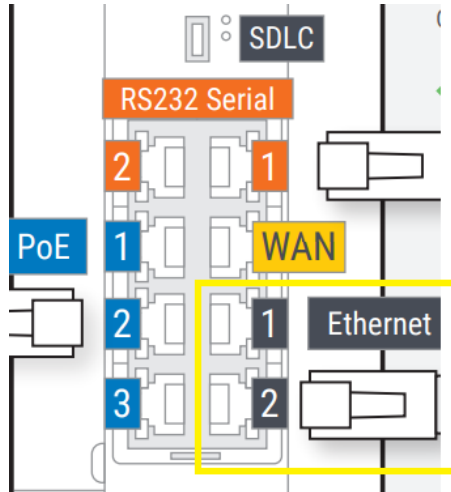

Note: Do not connect controller NTCIP into the WAN (yellow) port or serial ports (orange).

4. Connect the MMU to an available RS232 Serial (**orange**) port.

Note: these connectors are RJ45 but carry a serial signal. If the MMU has an Ethernet port, connect to an available Ethernet port on the Miovision Core.

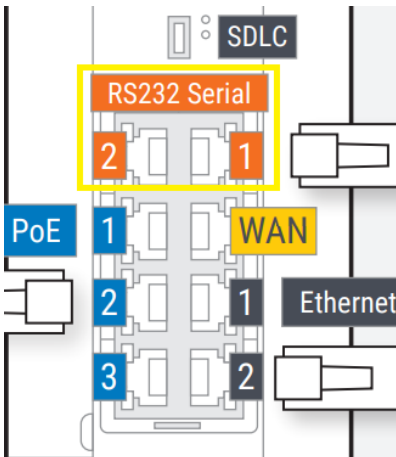

5. Connect the Ethernet cable from the SmartView 360 or SmartView Approach camera to an available PoE (**blue**). For multi-camera setups, ensure each camera's Ethernet cable is plugged into an available PoE port or use the Miovision approved PoE switch.

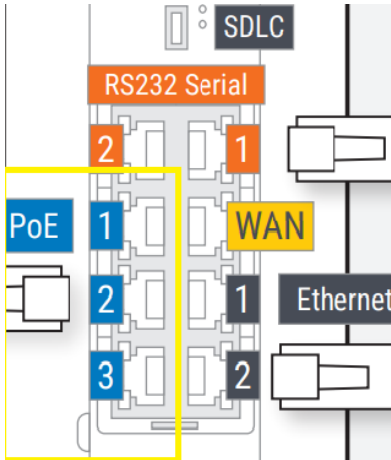

6. If telemetry over SDLC is required, connect the SDLC port on the Miovision Core to the cabinet SDLC bus using the provided SDLC Y-Cable (115-00048-001).
Note: You must use a CoreSDLC cable for compatibility. Using a previous generation SDLC cable is not supported by the Miovision Core device. Contact [Miovision Technical Support](#) for more information.

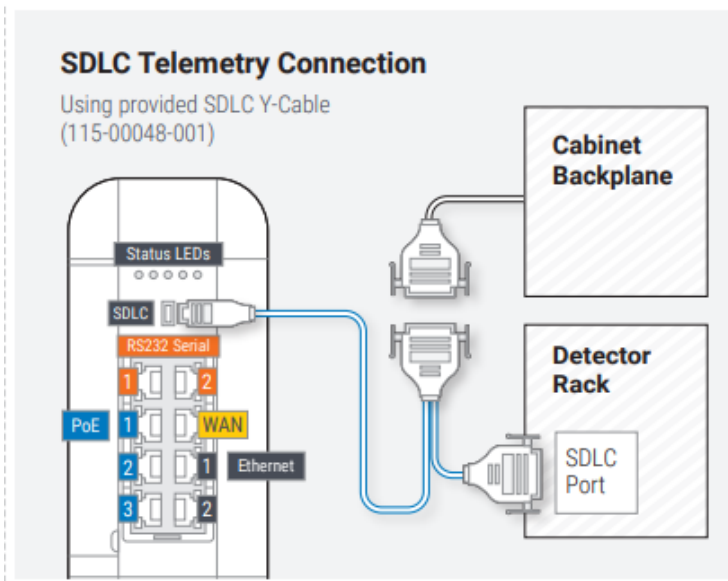

7. Plug or wire the other end of the AC power cord into the power source. Plug the AC power cord (NEMA 5-15) into the provided power adapter, ensuring a tight fit. If pigtail wires are required, cut the connector off the provided line cord.
Note: When plugging the Miovision Core into a power source, ensure a standard plug or power bar is used and not a GFCI receptacle. If a GFCI receptacle is the only power source, wire directly to a terminal block.
8. Plug the DC end of the power adapter into the connector located on the back of the Miovision Core. See “Start Up Miovision Core” below for information on how the device boots up once power is applied.

Note: Miovision Core receives isolated earth ground directly through the provided power adapter. If a stronger ground bond is required, attach cabinet earth ground to the grounding lug located above the power port, on the back of the device.

Start Up Miovision Core

Once the Miovision Core is installed into the cabinet, ensure the system starts up correctly. Verify that your device displays the following:



1. The Power LED is illuminated.
2. The Status LEDs are illuminated correctly.
 - a. Heartbeat: flashing blue.
 - b. VPN: solid blue.
 - c. WAN: solid blue.
 - d. Cell: solid blue.
 - e. State: flashing (booting) or solid (booted) blue.
3. If SDLC is connected properly, the Rx and Tx LEDs on the device will blink when there is active communications with the controller.

Status LEDs				
Heartbeat	VPN	WAN	Cell	State
Flashing Blue Device Operational	Solid Blue Connected to Miovision cloud	Solid Blue Connected to internet	Solid Blue Cell connected Flashing Yellow Searching for cell Solid Yellow Less than 25% cell signal Flashing Red Modem fault	Flashing Blue Device booting Solid Blue Device online Flashing Red Device fault Flashing Yellow Updating SW

Installing Miovision Core DCM

When installing the Miovision Core DCM device, complete the [Miovision Core](#) steps 1-3 first (above). You can also review the following steps in the [Miovision Core DCM Installation](#) video tutorial.

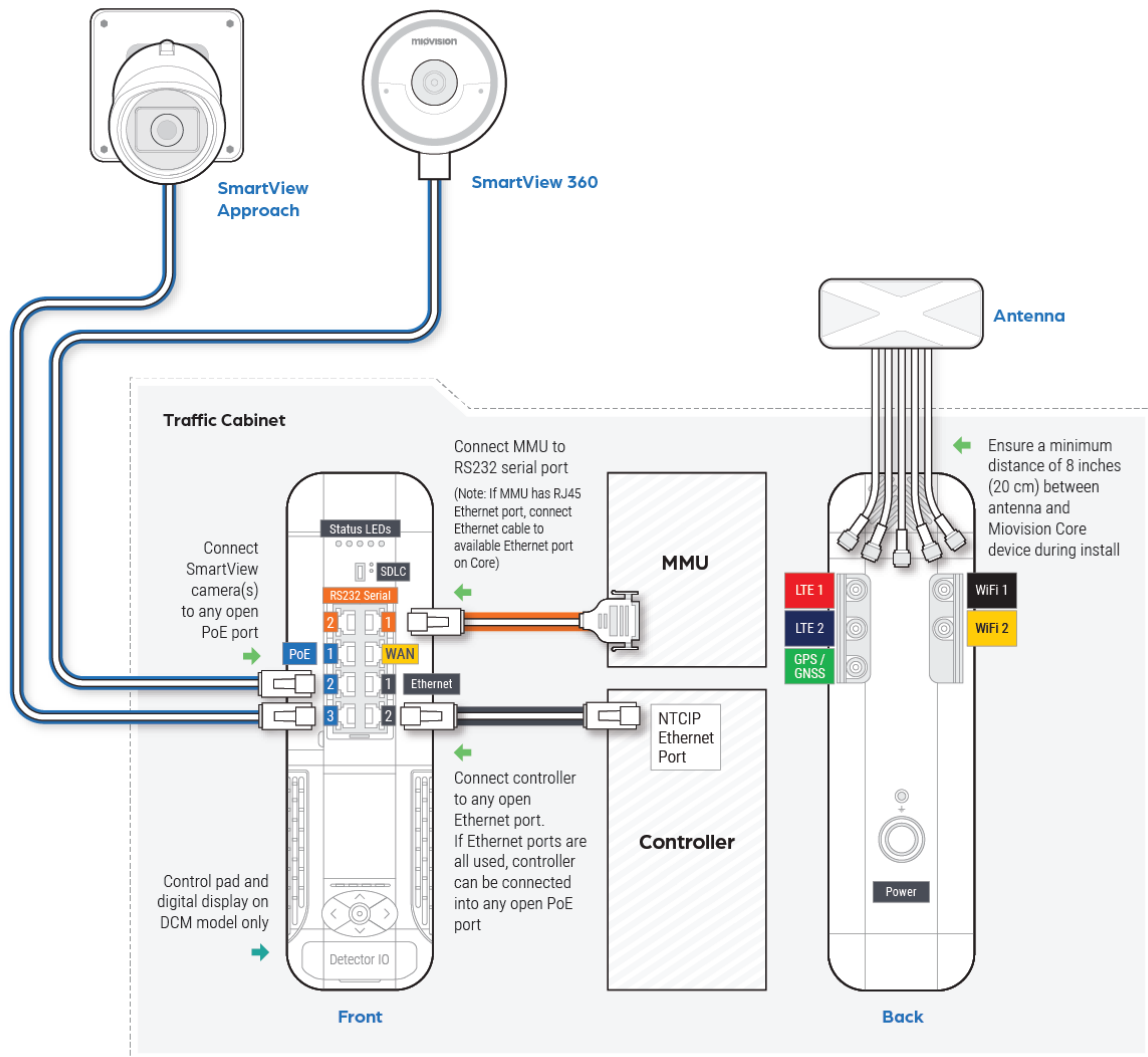

4. If actuation over SDLC is required, connect the SDLC port on Miovision Core DCM to the SDLC bus in the cabinet using the provided SDLC Y-Cable (115-00048-001). **Note:** You must use the provided SDLC cable for compatibility. Using a previous generation SDLC cable is not supported by the Miovision Core device. Contact [Miovision Technical Support](#) for more information.
5. Plug or wire the other end of the AC power cord into the power source. Plug the AC power cord into the provided power adapter, ensuring a tight fit. **Note:** When plugging the Miovision Core into a power source, ensure a standard plug or power bar is used, and not a GFCI receptacle. If a GFCI receptacle is the only power source, use the pigtail for terminal block wiring.

6. Plug the DC end of the power adapter into the connector located on the back of the Miovision Core. See “Starting Up Miovision Core” for information on how the device boots once power is applied.

Note: Miovision Core receives isolated earth ground directly through the provided power adapter. If a stronger ground bond is required, attach cabinet earth ground to the grounding lug located above the power port, on the back of the device.

Installation checklist

To ensure you complete all necessary steps to successfully install the Miovision Core at the intersection, bring a printed copy of the [Installation Checklist](#) to your roadside installation.

Set up the Miovision Core DCM

The following section is only relevant to the installation of the Miovision Core DCM. Contact Miovision support for more information.

Change the displayed language on Miovision Core DCM

Current language options are English or Canadian French.

1. Access the Main menu.
2. Press **Language**. The language screen will display the currently selected language.
3. To change the language, press **Select**.
4. Select the language you want to use.

Establish camera connectivity for Detection or Counting

To connect the camera to the device:

- The camera must be turned on and plugged into the Miovision Core PoE (Ethernet) port.
- The camera must be able to communicate with the network.
- The streaming service must be configured to detect the device.

Camera Status

1. From the main menu, press **System**.
2. Press **Cameras**.

This will display the list of cameras connected to the Core DCM, their IP addresses, and their connectivity status, including:

Status	Meaning	Next steps
Unreachable	The camera is plugged into the Miovision Core but is not communicating with the network.	Check for breaks in the cable.
Streaming-Unconfigured	The camera is plugged into the Miovision Core and is communicating with the network. The DCM has not yet been configured for Detection or Counting.	Configure DCM Detection/Counting if desired.
Conflict	The camera is plugged into the Miovision Core and is communicating with the network. The camera is using the same IP address as another connected device (likely, another camera).	Resolve IP Conflict. See: Resolving IP address conflicts .
Streaming-Passthru	The camera is plugged into the Miovision Core and is reachable. It is not being used for Detection or Counting by the DCM, and is simply serving as a camera stream source. In this state, it is likely that there is another camera that is successfully being used by the DCM for Detection or Counting.	If the camera needs to be used for Detection/Counting (e.g. as a Dual Camera), add it to the DCM Detection/Count configuration.
Booting or Fault	This status might display temporarily while the device boots, but is also displayed when there is a camera error.	If status persists, further investigation may be required. Contact Technical Support .

Streaming-Fault	The camera has established connectivity but there is a technical issue that has interrupted the streaming service and further investigation is required.	Contact Technical Support .
Streaming-Processing	The camera has established connectivity and is being processed for Detection and/or Counting as configured.	n/a

Resolving IP address conflicts

If a camera status is 'Conflict', you can resolve it at the roadside. The Miovision Core DCM **Install** menu will also be marked with an asterisk (*).

1. Press **System**.
2. Press **Cameras**.
3. Use the panel buttons to toggle to the camera with the status **Conflict**. Select it..
4. Use the panel buttons to select a unique IP address that does not have an asterisk beside it and press to apply it. Record the IP address that you selected, since you will need to assign it to the device in the TrafficLink portal. It can take up to 25 seconds to update the IP address. When it is successful, the camera status returns to **Streaming-Processing, Streaming-Passthru, or Streaming-Unconfigured**.
Note: IP addresses that are already in use by other devices that are connected to the Miovision Core are not displayed in the list.
5. To assign the IP address to the device in the TrafficLink portal, see [Configuring TrafficLink Detection in TrafficLink portal](#).

Configuration in TrafficLink

If Detection/Counting has already been configured in TrafficLink, your full system setup is complete.

If you have not completed this Configuration yet, please see the document **Configuring Core DCM for Detection and Counts in TrafficLink**.

An Installation Checklist is available on the DCM front panel:

1. From the front panel of Miovision Core DCM, press **Install**.
2. Press **Select**.

Camera port(s)	The camera status should read Streaming-Processing .
Miovision Core	The status should read Up . If the status reads Down : <ul style="list-style-type: none"> ● The Ethernet cable might be damaged or not connected properly to a port on the Miovision Core.
WAN	The status should read Up . If the status reads Down , the Miovision Core is not currently providing the Miovision Core DCM access to TrafficLink.
CONFIG	The status should read TMC+DET, DET, or TMC . If the status reads None , the Miovision Core DCM needs to be configured in TrafficLink.
ACTUATE	If the Miovision Core DCM is configured, the status should read Actuating if you have already added the DCM device to the intersection in TrafficLink, or configured it for actuation mode. The DCM can be configured in TrafficLink so that detector calls are not sent to the controller. The status displays as Non-Actuate.
MODE	Ensure that the actuation mode matches the controller type. This status should read either ABC, SDLC, GPIO or None . If the actuation mode is SDLC , the display indicates when the Miovision Core DCM is receiving and responding to SDLC requests. An R and T character is displayed to represent the Receiving and Transmitting status. When a transmission is in progress, a square icon blinks next to the applicable character. If only the R character is displayed and a DCM detection configuration is deployed in TrafficLink, confirm that the detector rack is enabled on the controller.
LOCATION	If the Miovision Core DCM is configured, the location

	should match the intersection name in TrafficLink.
--	--

Monitor Miovision Core DCM Detection

Once a system has been fully installed and configured, you can use the front panel to view the states of all the configured detector channels.

View Miovision Core DCM Detectors

All configured channels are displayed on one menu, regardless of how many are configured. For SDLC installations, the range of channels that are displayed corresponds to the Detector Rack you configured for your channels in TrafficLink.

1. To view the Detectors menu, use the up and down arrow buttons on the main menu..
2. Press the Select button or the right arrow button to view the detectors.
Detector Racks are mapped as follows:

Detector Rack	Controller Channels
1	1 through 16
2	17 through 32
3	33 through 48
4	49 through 64

Note: If the Miovision Core I/O Configuration setting is set to **None** in TrafficLink to disable actuation, ACTOFF is displayed on the screen and no detectors are shown.

Determining the status of detectors

1. From the front panel, press **Legend**.

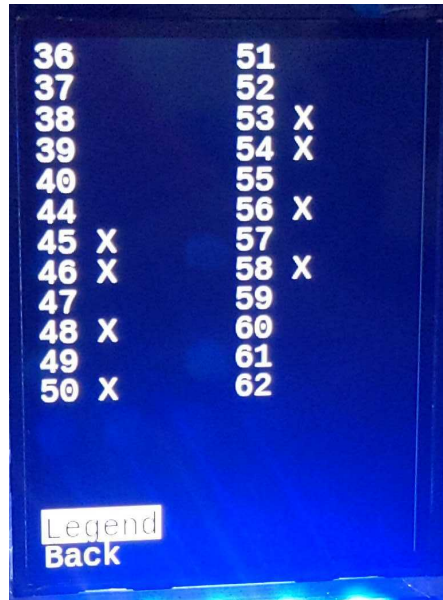

X	The detector is active and actuating normally.
R	The detector was activated manually in the TrafficLink portal.
F	The detector was activated after entering a failsafe mode or a degraded state, such as when a camera is disconnected.

Upgrade Miovision Core to Miovision Core DCM

If your Miovision Core was purchased without video detection capability, it ships with a Fan Control Module (FCM). This is the black module at the bottom of the device with an orange release button. To upgrade the Miovision Core to enable detection and counts, the FCM will need to be removed and replaced with the supplied DCM module.

Note: Unplug the Miovision Core device first. Never perform a swap while the unit is operating.

1. Press in the orange button on the side of the FCM to remove from the Miovision Core. Apply pressure with your hands so the unit slides out.

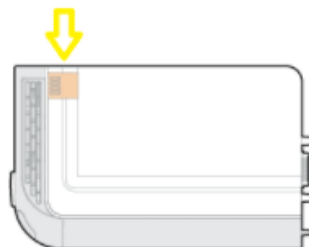

- Place the FCM in a safe location or lay it flat on its side while you hold the Miovision Core device. Keep this module for future use.
Note: If you are replacing a significant number of FCMs, contact Miovision Customer Support to learn how to safely dispose of the modules..
- Slide the DCM into the Miovision Core and listen for it to “click” into place. The DCM module should fit in the Miovision Core securely.

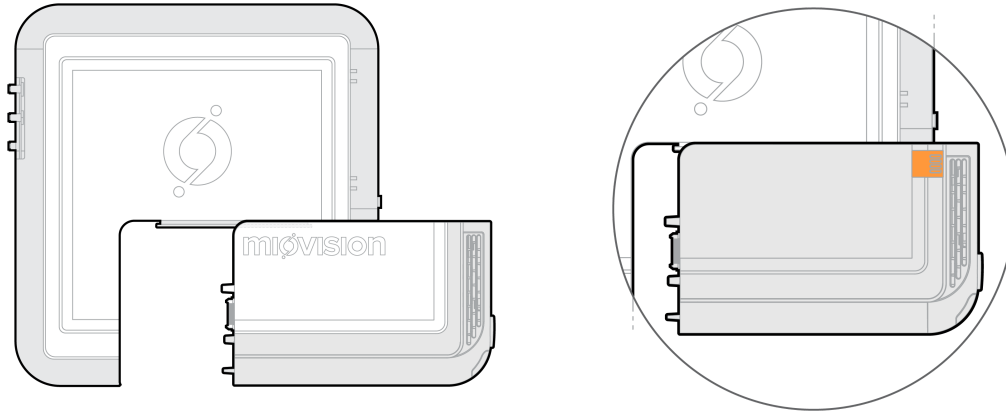

Note: The Miovision Core modules must be inserted into the guide features correctly as shown above. Incorrectly inserting Miovision Core modules may result in damage to the device.

- Once the DCM has been inserted, plug the unit back in. Miovision Core will apply power to the module and the screen will turn on. Once the DCM has fully booted it will show up in the TrafficLink portal. Once the connection is complete, [set up the Miovision Core DCM](#).

Restarting Miovision Core

There are three options for restarting the Miovision Core device.

The device at the traffic cabinet	Press and hold the illuminated Miovision logo power button.
The device at the traffic cabinet	Unplug the Core, wait until the device powers off completely, and plug the device back in again.

Remotely from the TrafficLink portal

Contact Miovision Technical Support (support@miovision.com) for assistance if this option is required..

Review the Traffic Cabinet Before Leaving the Intersection

Follow these steps before closing the traffic cabinet.

1. Verify that the TrafficLink antenna is securely attached to the top of the cabinet.
2. Confirm that the LEDs on the Core device appear as follows:

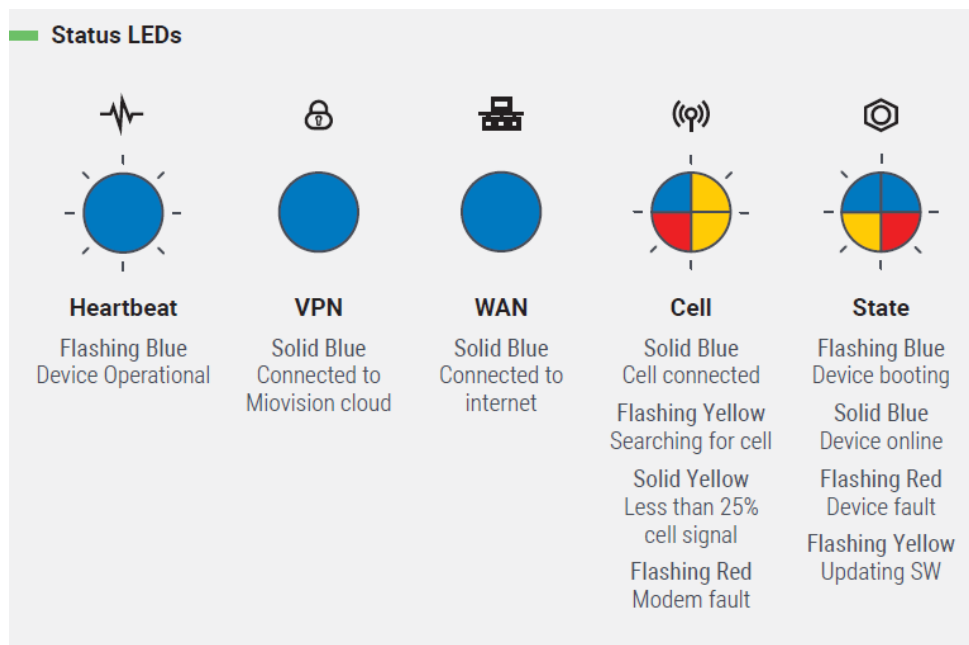

3. If any of the tests fail, check that all cables and power supplies are properly connected. If issues still exist, contact Miovision TechnicalSupport (support@miovision.com).
4. Take the following photos as part of the installation checklist:
 - A photo of the inside of the traffic cabinet that shows the placement of the Miovision Core components
 - A photo of the timing plan and wiring diagram (typically, the diagram is found in the cabinet pouch).
5. Fill out the [Installation checklist](#).

Miovision Technical Support

Technical support is available five days a week by live chat in TrafficLink portal, phone, or email during regular business hours (Monday-Friday, 7 am-6 pm EST/EDT). Certain restrictions and exclusions apply.

Online: https://help.miovision.com/s/?language=en_US

Phone: 1-855-360-7752

Email: support@miovision.com